

# Structural SBS450 Bar System

## The System

The standard tie bar system comprises of a bar with a left hand and right hand threaded SBS-450 fork at opposite ends. Once installed the bar can be rotated to expand or contract the fork's pin centres. Special spanner flats can be added at the ends of the tie bars to facilitate rotation. The ADJ value in the table below details the amount of adjustment at each fork end. Once installed the forks are locked into position by tightening the tapered locking nuts using a 'C' pin spanner. The special tapered locking nuts also hide excessive bar threads. The forks benefit from 'Double Headed' clevis pins which are fastened into position using a standard 'Allen' key.

## The Applications

Modern developments in construction technology have focused on the production of light sturdy structures. Bar-braced structures are a key part of current systems and can be expected to further increase in relevance. It is our policy to be at the forefront of developing such economic and versatile technologies. By combining an understanding of the relevant aesthetic and scientific principles, we are able to provide elegant yet reliable solutions to tension member problems. The SBS450 system is made from high grade materials resulting in extra strength and at the same time demonstrates design features such as the tapered locking nut which hides bar threads thus providing a clean cosmetic appearance.

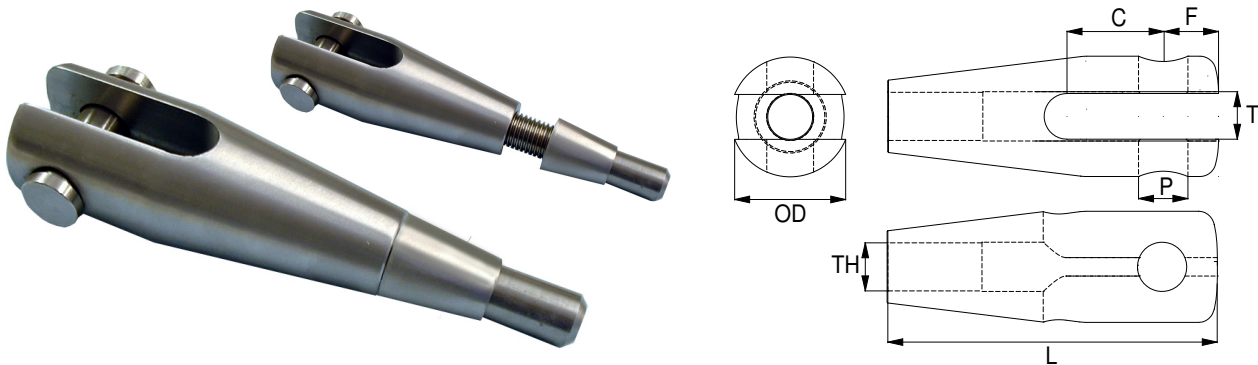

ADJ = Total Adjustment

PART CODE	THREAD (Metric)	PIN P	T	C	F	ADJ	OD	L	0.2% kN *	UTS kN *
SBFM10	M10 x 1.50	10mm	10mm	20mm	11.2mm	20mm	25mm	68.7mm	26.1	40.6
SBFM12	M12 x 1.75	12mm	12mm	24mm	13.8mm	24mm	32mm	82.8mm	37.8	58.8
SBFM16	M16 x 2.00	16mm	15mm	32mm	18.4mm	32mm	40mm	109.9mm	70.7	109.9
SBFM20	M20 x 2.50	20mm	19mm	40mm	23.0mm	40mm	50mm	137.5mm	110.3	171.5
SBFM24	M24 x 3.00	24mm	24mm	48mm	27.6mm	48mm	60mm	165.6mm	158.9	247.1
SBFM27	M27 x 3.00	27mm	26mm	54mm	31.1mm	54mm	70mm	185.9mm	206.6	321.3
SBFM30	M30 x 3.50	30mm	29mm	60mm	34.5mm	60mm	75mm	206.5mm	252.6	485.8
SBFM33	M33 x 3.50	33mm	32mm	66mm	38.0mm	66mm	80mm	227.3mm	312.3	571.9
SBFM36	M36 x 4.00	36mm	34mm	72mm	41.4mm	72mm	90mm	247.4mm	367.7	638.2
SBFM39	M39 x 4.00	39mm	38mm	78mm	44.9mm	78mm	100mm	268.7mm	439.2	784.7

Sizes above M39 also available - please contact us for further details.

\*in accordance with BS5950-1:2000 and EN 1993-1-8:2005

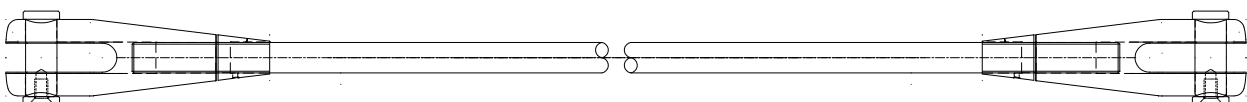

## Technical Data

The SBS-450 forks and pins are manufactured from a Duplex grade of stainless steel which offers higher corrosion resistance and mechanical properties than marine grade 316 (EN10088 1.4401). Designed in accordance with BS 5950-1:2000 and EN 1993-1-8:2005. All components are produced at our manufacturing facility in the North of the England using the latest technology in CNC equipment. They are manufactured in accordance with our quality systems and finished to a N4 standard (240 grit satin). Bar lengths are available up to 6m. Lengths exceeding 6m are also available by utilising a bar coupler.